

Smart Fiber Sensor E3NX-FA

CSM_E3NX-FA_DS_E_1_1

The Advanced Fiber Sensor That Handles On-site Needs



- Improved basic performance with 1.5 times the sensing distance and approx. 1/10th the minimum sensing object.*
- Ultra-easy setup with Smart Tuning with a dynamic range expanded 20 times to 40,000:1. Optimum stable detection achieved with light level adjustment even for saturated incident light.
- White on black display characters for high visibility.
- Solution Viewer that shows the passing time and difference in incident levels and Change Finder that shows even high-speed workpieces to achieve simple settings and reliable detection.







* Compared to the E3X-HD.

 Refer to the *Safety Precautions* on page 12.

For the most recent information on models that have been certified for safety standards, refer to your OMRON website.

Ordering Information





Fiber Amplifier Units (Dimensions → pages 13 and 14)

Type	Connecting method	Appearance	Inputs/outputs	Model	
				NPN output	PNP output
Standard models	Pre-wired (2 m)		1 output	E3NX-FA11 2M	E3NX-FA41 2M
	Wire-saving Connector		1 output	E3NX-FA6	E3NX-FA8
Advanced models	Pre-wired (2 m)		2 outputs + 1 input	E3NX-FA21 2M	E3NX-FA51 2M
	Wire-saving Connector		1 output + 1 input	E3NX-FA7	E3NX-FA9
			2 outputs	E3NX-FA7TW	E3NX-FA9TW
Model for Sensor Communications Unit	Connector for Sensor Communications Unit		2 outputs	E3NX-FA0 Available soon.	

Accessories (Sold Separately)

Wire-saving Connectors (Required for models for Wire-saving Connectors.) (Dimensions → page 14)

Connectors are not provided with the Fiber Amplifier Unit and must be ordered separately. *Protective stickers are provided.

Type	Appearance	Cable length	No. of conductors	Model	Applicable Fiber Amplifier Units
Master Connector		2 m	4	E3X-CN21	E3NX-FA7 E3NX-FA7TW E3NX-FA9 E3NX-FA9TW
Slave Connector			2	E3X-CN22	
Master Connector			3	E3X-CN11	E3NX-FA6 E3NX-FA8
Slave Connector			1	E3X-CN12	

Mounting Bracket (Dimensions → page 15)

A Mounting Bracket is not provided with the Fiber Amplifier Unit. It must be ordered separately as required.

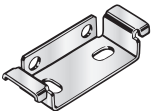
Appearance	Model	Quantity
	E39-L143	1

DIN Track (Dimensions → page 15)

A DIN Track is not provided with the Fiber Amplifier Unit. It must be ordered separately as required.

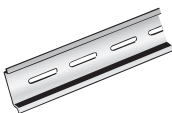
Appearance	Type	Model	Quantity
	Shallow type, total length: 1 m	PFP-100N	1
	Shallow type, total length: 0.5 m	PFP-50N	
	Deep type, total length: 1 m	PFP-100N2	

End Plate (Dimensions → page 15)



Two End Plates are provided with the Sensor Communications Unit.

End Plates are not provided with the Fiber Amplifier Unit. They must be ordered separately as required.

Appearance	Model	Quantity
	PFP-M	1

Related Products

Sensor Communications Units (Dimensions → page 16)

Type	Appearance	Model
Sensor Communications Unit for EtherCAT*		E3NW-ECT Available soon.
Sensor Dispersion Unit		E3NW-DS Available soon.

* EtherCAT® is a registered trademark and patented technology, licensed by Beckhoff Automation GmbH, Germany.

Ratings and Specifications

Item		Type	Standard models		Advanced models			Model for Sensor Communications Unit
		NPN output	E3NX-FA11	E3NX-FA6	E3NX-FA21	E3NX-FA7	E3NX-FA7TW	E3NX-FA0
		PNP output	E3NX-FA41	E3NX-FA8	E3NX-FA51	E3NX-FA9	E3NX-FA9TW	Available soon.
		Connecting method	Pre-wired	Wire-saving Connector	Pre-wired	Wire-saving Connector	Connector for Sensor Communications Unit	
Inputs/outputs	Outputs	1 output		2 outputs	1 output	2 outputs	2 outputs	
	External inputs	---		1 input	1 input	---	---	
Light source (wavelength)		Red, 4-element LED (625 nm)						
Power supply voltage		10 to 30 VDC, including 10% ripple (p-p)						
Power consumption*1		At Power Supply Voltage of 24 VDC Standard Models or Model for Sensor Communications Unit: Normal mode: 960 mW max. (Current consumption: 40 mA max.), Power saving eco mode: 840 mW max. (Current consumption: 35 mA max.) Advanced Models: Normal mode: 1,080 mW max. (Current consumption: 45 mA max.), Power saving eco mode: 930mW max. (Current consumption: 40 mA max.)						
Control output		Load power supply voltage: 30 VDC max., open-collector output Load current: Groups of 1 to 3 Amplifiers: 100 mA max., Groups of 4 to 30 Amplifiers: 20 mA max. (Residual voltage: At load current of less than 10 mA: 1 V max. At load current of 10 to 100 mA: 2 V max.) OFF current: 0.1 mA max.					---	
External inputs		---		Refer to *2.		---		
Indicators		7-segment displays (Sub digital display: green, Main digital display: white) Display direction: Switchable between normal and reversed. OUT indicator (orange), L/D indicator (orange), ST indicator (blue), DPC indicator (green), and OUT selection indicator (orange, only on models with 2 outputs)						
Protection circuits		Power supply reverse polarity protection, output short-circuit protection, and output reverse polarity protection					Power supply reverse polarity protection and output short-circuit protection	
Response time	Super-high-speed mode (SHS)*3	Operate or reset for model with 1 output: 30 μs, with 2 outputs: 32 μs						
	High-speed mode (HS)	Operate or reset: 250 μs						
	Standard mode (Std)	Operate or reset: 1 ms						
	Giga-power mode (GIGA)	Operate or reset: 16 ms						
Sensitivity adjustment		Smart Tuning (2-point tuning, full auto tuning, position tuning, maximum sensitivity tuning, power tuning, or percentage tuning (-99% to 99%)) or manual adjustment						
No. of Units for mutual interference prevention	Super-high-speed mode (SHS)*3	0						
	High-speed mode (HS)	10						
	Standard mode (Std)	10						
	Giga-power mode (GIGA)	10						
Functions	Automatic power control (APC)	Always enabled.						
	Dynamic power control (DPC)	Provided						
	Timer	Select from timer disabled, OFF-delay, ON-delay, one-shot, or ON-delay + OFF-delay timer: 1 to 9,999 ms						
	Zero reset	Negative values can be displayed. (Threshold value is shifted.)						
	Resetting settings*4	Select from initial reset (factory defaults) or user reset (saved settings).						

*1. At Power Supply Voltage of 10 to 30 VDC.

Standard Models or Model for Sensor Communications Unit:

Normal mode: 1,080 mW max. (Current consumption: 36 mA max. at 30 VDC, 108 mA max. at 10 VDC)

Power saving eco mode: 930 mW max. (Current consumption: 31 mA max. at 30 VDC, 93 mA max. at 10 VDC)

Advanced Models:

Normal mode: 1,230 mW max. (Current consumption: 41 mA max. at 30 VDC, 123 mA max. at 10 VDC)

Power saving eco mode: 1,050 mW max. (Current consumption: 35 mA max. at 30 VDC, 105 mA max. at 10 VDC)

*2. The following details apply to the input.

	Contact input (relay or switch)	Non-contact input (transistor)	Input time
NPN	ON: Shorted to 0 V (Sourcing current: 1 mA max.). OFF: Open or shorted to Vcc.	ON: 1.5 V max. (Sourcing current: 1 mA max.) OFF: Vcc - 1.5 V to Vcc (Leakage current: 0.1 mA max.)	ON: 2 ms min. OFF: 20 ms min.
PNP	ON: Shorted to Vcc (Sinking current: 3 mA max.). OFF: Open or shorted to 0 V.	ON: Vcc - 1.5 V to Vcc (Sinking current: 3 mA max.) OFF: 1.5 V max. (Leakage current: 0.1 mA max.)	

*3. The mutual interference prevention function is disabled if the detection mode is set to super-high-speed mode.

*4. The bank is not reset by the user reset function or saved by the user save function.

Item	Type	Standard models		Advanced models			Model for Sensor Communications Unit
	NPN output	E3NX-FA11	E3NX-FA6	E3NX-FA21	E3NX-FA7	E3NX-FA7TW	E3NX-FA0
	PNP output	E3NX-FA41	E3NX-FA8	E3NX-FA51	E3NX-FA9	E3NX-FA9TW	Available soon.
	Connecting method	Pre-wired	Wire-saving Connector	Pre-wired	Wire-saving Connector		Connector for Sensor Communications Unit
Functions	Eco mode	Select from OFF (digital displays lit) or ECO (digital displays not lit).					
	Bank switching	Select from banks 1 to 4.					
	Power tuning	Select from ON or OFF.					
	Output 1	Select from normal detection mode or area detection mode.					
	Output 2	---		Select from normal detection mode, alarm output mode, or error output mode.	---		Select from normal detection mode, alarm output mode, or error output mode.
	External input	---		Select from input OFF, tuning, power tuning, emission OFF, zero reset, or bank switching.	---		
	Hysteresis width	Select from standard setting or user setting. For a user setting, the hysteresis width can be set to from 1 to 9,999.					
Ambient illumination		Incandescent lamp: 20,000 lx max., Sunlight: 30,000 lx max.					
Maximum connectable Units		30					
Ambient temperature range		<p>Operating: Groups of 1 or 2 Amplifiers: -25 to 55°C, Groups of 3 to 10 Amplifiers: -25 to 50°C, Groups of 11 to 16 Amplifiers: -25 to 45°C, Groups of 17 to 30 Amplifiers: -25 to 40°C Storage: -30 to 70°C (with no icing or condensation)</p>				<p>Operating: Groups of 1 or 2 Amplifiers: 0 to 55°C, Groups of 3 to 10 Amplifiers: 0 to 50°C, Groups of 11 to 16 Amplifiers: 0 to 45°C, Groups of 17 to 30 Amplifiers: 0 to 40°C Storage: -30 to 70°C (with no icing or condensation)</p>	
Ambient humidity range		Operating and storage: 35% to 85% (with no condensation)					
Insulation resistance		20 MΩ min. (at 500 VDC)					
Dielectric strength		1,000 VAC at 50/60 Hz for 1 minute					
Vibration resistance (destruction)		10 to 55 Hz with a 1.5-mm double amplitude for 2 hours each in X, Y, and Z directions					
Shock resistance (destruction)		500 m/s ² for 3 times each in X, Y, and Z directions				150 m/s ² for 3 times each in X, Y, and Z directions	
Weight (packed state/Sensor only)		Approx. 115 g/ approx. 75 g	Approx. 60g/ approx. 20g	Approx. 115 g/ approx. 75 g	Approx. 60g/approx. 20g		Approx. 65 g/ approx. 25 g
Materials	Case	Polycarbonate (PC)					
	Cover	Polycarbonate (PC)					
	Cable	PVC					
Accessories		Instruction Manual					

Sensing Distances

Threaded Models

Sensing method	Sensing direction	Size	Model	Sensing distance (mm)			
				Giga mode	Standard mode	High-speed mode	Super-high-speed mode
Through-beam	Right-angle	M4	E32-T11N 2M	3,000	1,500	1,050	280
	Straight		E32-T11R 2M				
			E32-LT11 2M	4,000*1	4,000*1	4,000*1	1,080
			E32-LT11R 2M	4,000*1	4,000*1	3,450	920
Reflective	Right-angle	M3	E32-C31N 2M	160	75	69	14
		M6	E32-C11N 2M	1,170	520	480	100
	Straight	M3	E32-D21R 2M	210	90	60	16
			E32-C31 2M	490	220	150	44
		E32-C31M 1M					
		M4	E32-D211R 2M	210	90	60	16
		M6	E32-D11R 2M	1,260	520	360	100
			E32-CC200 2M	2,100	900	600	180
			E32-LD11 2M	1,290	540	370	110
			E32-LD11R 2M	1,260	520	360	100

*1. The fiber length is 2 m on each side, so the sensing distance is given as 4,000 mm.

Cylindrical Models

Sensing method	Size	Sensing direction	Model	Sensing distance (mm)			
				Giga mode	Standard mode	High-speed mode	Super-high-speed mode
Through-beam	1 dia.	Top-view	E32-T223R 2M	670	370	220	60
	1.5 dia.		E32-T22B 2M	1,020	600	330	90
	3 dia.		E32-T12R 2M	3,000	1,500	1,050	280
	3 dia.	Side-view	E32-T14LR 2M	1,120	670	390	100
Reflective	1.5 dia.	Top-view	E32-D22B 2M	210	90	60	16
	1.5 dia. + 0.5 dia.		E32-D43M 1M	42	18	12	4
			E32-D22R 2M	210	90	60	16
	3 dia.		E32-D221B 2M	450	210	130	40
			E32-D32L 2M	1,050	450	300	90
	3 dia. + 0.8 dia.		E32-D33 2M	100	45	30	8

Flat Models

Sensing method	Sensing direction	Model	Sensing distance (mm)			
			Giga mode	Standard mode	High-speed mode	Super-high-speed mode
Through-beam	Top-view	E32-T15XR 2M	3,000	1,500	1,050	280
	Side-view	E32-T15YR 2M	1,120	670	390	100
	Flat-view	E32-T15ZR 2M				
Reflective	Top-view	E32-D15XR 2M	1,260	520	360	100
	Side-view	E32-D15YR 2M	300	150	78	24
	Flat-view	E32-D15ZR 2M				

Sleeve Models

Sensing method	Sensing direction	Model	Sensing distance (mm)			
			Giga mode	Standard mode	High-speed mode	Super-high-speed mode
Through-beam	Side-view	E32-T24R 2M	250	150	75	20
		E32-T24E 2M	670	370	220	60
	Top-view	E32-T33 1M	220	130	75	20
		E32-T21-S1 2M	760	450	250	68
		E32-TC200BR 2M	3,000	1,500	1,050	280
Reflective	Side-view	E32-D24R 2M	100	45	30	8
		E32-D24-S2 2M	180	79	67	14
	Top-view	E32-D43M 1M	42	18	12	4
		E32-D331 2M	21	9	6	2
		E32-D33 2M	100	45	30	8
		E32-D32-S1 0.5M	94	40	27	7
		E32-D31-S1 0.5M				
		E32-DC200F4R 2M	210	90	60	16
		E32-D22-S1 2M	370	160	100	30
		E32-D21-S3 2M				
		E32-DC200BR 2M	1,260	520	360	100
		E32-D25-S3 2M	370	160	100	30

Small-spot, Reflective Models

Type	Spot diameter	Center distance (mm)	Models	Sensing distance (mm)			
				Giga mode	Standard mode	High-speed mode	Super-high-speed mode
Variable spot	0.1 to 0.6 dia.	6 to 15	E32-C42 1M + E39-F3A	Spot diameter of 0.1 to 0.6 mm at 6 to 15 mm.			
	0.3 to 1.6 dia.	10 to 30	E32-C42 1M + E39-F17	Spot diameter of 0.3 to 1.6 mm at 10 to 30 mm.			
Parallel light	4 dia.	0 to 20	E32-C31 2M + E39-F3C	Spot diameter of 4 mm max. at 0 to 20 mm.			
			E32-C31N 2M + E39-F3C				
Integrated lens	0.1 dia.	5	E32-C42S 1M	Spot diameter of 0.1 mm at 5 mm.			
	6 dia.	50	E32-L15 2M	Spot diameter of 6 mm at 50 mm.			
Small-spot	0.1 dia.	7	E32-C41 1M + E39-F3A-5	Spot diameter of 0.1 mm at 7 mm.			
			E32-C31 2M + E39-F3A-5	Spot diameter of 0.5 mm at 7 mm.			
	E32-C31N 2M + E39-F3A-5						
	0.2 dia.	17	E32-C41 1M + E39-F3B	Spot diameter of 0.2 mm at 17 mm.			
			E32-C31 2M + E39-F3B	Spot diameter of 0.5 mm at 17 mm.			
	E32-C31N 2M + E39-F3B						
3 dia.	50	E32-CC200 2M + E39-F18	Spot diameter of 3 mm at 50 mm.				
		E32-C11N 2M + E39-F18					

High-power Beam Models

Type	Sensing direction	Aperture angle	Models	Sensing distance (mm)			
				Giga mode	Standard mode	High-speed mode	Super-high-speed mode
Through-beam models with integrated lens	Top-view	10°	E32-T17 10M	20,000*1	20,000*1	20,000*1	8,000
		15°	E32-LT11 2M	4,000*2	4,000*2	4,000*2	1,080
	E32-LT11R 2M		4,000*2	4,000*2	3,450	920	
Side-view	30°	E32-T14 2M	4,000*2	4,000*2	4,000*2	1,800	
Through-beam models with lenses	Right-angle	12°	E32-T11N 2M + E39-F1	4,000*2	4,000*2	4,000*2	2,000
		6°	E32-T11N 2M + E39-F16	4,000*2	4,000*2	4,000*2	3,600
	Top-view	12°	E32-T11R 2M + E39-F1	4,000*2	4,000*2	4,000*2	2,000
		6°	E32-T11R 2M + E39-F16	4,000*2	4,000*2	4,000*2	3,600
	Side-view	60°	E32-T11R 2M + E39-F2	2,170	1,200	750	200
	Top-view	12°	E32-T11 2M + E39-F1	4,000*2	4,000*2	4,000*2	1,860
		6°	E32-T11 2M + E39-F16	4,000*2	4,000*2	4,000*2	4,000*2
	Side-view	60°	E32-T11 2M + E39-F2	3,450	1,980	1,290	320
	Top-view	12°	E32-T51R 2M + E39-F1	4,000*2	4,000*2	4,000*2	1,500
		6°	E32-T51R 2M + E39-F16	4,000*2	4,000*2	4,000*2	4,000*2
	Side-view	60°	E32-T51R 2M + E39-F2	2,100	1,080	750	200
	Top-view	12°	E32-T81R-S 2M + E39-F1	4,000*2	4,000*2	4,000*2	1,000
		6°	E32-T81R-S 2M + E39-F16	4,000*2	4,000*2	4,000*2	1,800
	Side-view	60°	E32-T81R-S 2M + E39-F2	1,500	820	540	140
	Top-view	12°	E32-T61-S 2M + E39-F1	4,000*2	4,000*2	4,000*2	1,800
		6°	E32-T61-S 2M + E39-F16	4,000*2	4,000*2	4,000*2	3,100
Side-view	60°	E32-T61-S 2M + E39-F2	2,520	1,350	900	240	
Top-view	12°	E32-T51 2M + E39-F1-33	4,000*2	4,000*2	3,450	1,400	
	6°	E32-T51 2M + E39-F16	4,000*2	4,000*2	4,000*2	4,000*2	
Reflective models with integrated lens	Top-view	4°	E32-D16 2M	40 to 4,000 *2	40 to 2,100	40 to 1,350	40 to 480

*1. The fiber length is 10 m on each side, so the sensing distance is given as 20,000 mm.

*2. The fiber length is 2 m on each side, so the sensing distance is given as 4,000 mm.

Narrow View Models

Sensing method	Sensing direction	Aperture angle	Models	Sensing distance (mm)				
				Giga mode	Standard mode	High-speed mode	Super-high-speed mode	
Through-beam	Side-view	1.5°	E32-A03 2M	4,000*1	2,670	1,800	500	
			E32-A03-1 2M					
		3.4°	E32-A04 2M	1,920	1,020	670	200	
			4°	E32-T24SR 2M	4,000*1	3,300	2,190	580
				E32-T24S 2M	4,000*1	3,900	2,610	700
E32-T22S 2M	4,000*1	4,000*1	3,750	1,000				

*1. The fiber length is 2 m on each side, so the sensing distance is given as 4,000 mm.

Models for Detection without Background Interference

Sensing method	Sensing direction	Model	Sensing distance (mm)			
			Giga mode	Standard mode	High-speed mode	Super-high-speed mode
Limited-reflective	Flat-view	E32-L16-N 2M	0 to 15			0 to 12
		E32-L24S 2M	0 to 4			
	Side-view	E32-L25L 2M	5.4 to 9 (center 7.2)			

Transparent Object Detection (Retro-reflective Models)

Sensing method	Feature	Size	Models	Sensing distance (mm)			
				Giga mode	Standard mode	High-speed mode	Super-high-speed mode
Retro-reflective	Film detection	M3	E32-C31 2M + E39-F3R + E39-RP37	370		300	---
	Square	---	E32-R16 5M	150 to 2,250			150 to 1,500
	Threaded	M6	E32-R21 2M	10 to 370			10 to 250

Transparent Object Detection (Limited-reflective Models)

Sensing method	Feature	Sensing direction	Model	Sensing distance (mm)			
				Giga mode	Standard mode	High-speed mode	Super-high-speed mode
Limited-reflective	Small size	Flat-view	E32-L24S 2M	0 to 4			
	Standard		E32-L16-N 2M	0 to 15		0 to 12	
	Glass substrate alignment, 70°C		E32-A08 2M	10 to 20		---	
	Standard/long-distance		E32-A12 2M	12 to 30		---	
	Side-view form	Side-view	E32-L25L 2M	5.4 to 9 (center 7.2)			
	Glass substrate mapping, 70°C	Top-view	E32-A09 2M	15 to 38			---

Chemical-resistant, Oil-resistant Models

Sensing method	Type	Sensing direction	Model	Sensing distance (mm)			
				Giga mode	Standard mode	High-speed mode	Super-high-speed mode
Through-beam	Oil-resistant	Right-angle	E32-T11NF 2M	4,000*1	4,000*1	4,000*1	2,200
	Chemical/oil-resistant	Top-view	E32-T12F 2M	4,000*1	4,000*1	4,000*1	1,600
		Side-view	E32-T11F 2M	4,000*1	4,000*1	3,900	1,000
			E32-T14F 2M	2,100	1,200	750	200
	Chemical/oil-resistant at 150°C	Top-view	E32-T51F 2M	4,000*1	4,000*1	2,700	700
Reflective	Semiconductors: Cleaning, developing, and etching; 60°C	Top-view	E32-L11FP 5M	8 to 20 mm from tip of lens (Recommended sensing distance: 11 mm), 19 to 31 mm from center of mounting hole A (Recommended sensing distance: 22 mm)			
	Semiconductors: Resist stripping; 85°C		E32-L11FS 5M	8 to 20 mm from tip of lens (Recommended sensing distance: 11 mm), 32 to 44 mm from center of mounting hole A (Recommended sensing distance: 35 mm)			
	Chemical/oil-resistant		E32-D12F 2M	---*2	280	190	60
	Chemical-resistant cable		E32-D11U 2M	1,260	520	360	100

*1. The fiber length is 2 m on each side, so the sensing distance is given as 4,000 mm.

*2. Even if there is no sensing object, the Sensor will detect light that is reflected by the fluorescein.

Bending-resistant Models

Sensing method	Size	Model	Sensing distance (mm)			
			Giga mode	Standard mode	High-speed mode	Super-high-speed mode
Through-beam	1.5 dia.	E32-T22B 2M	1,020	600	330	90
	M3	E32-T21 2M				
	M4	E32-T11 2M	3,750	2,020	1,350	360
	Square	32-T25XB 2M	750	450	250	70
Reflective	1.5 dia.	E32-D22B 2M	210	90	60	16
	M3	E32-D21 2M				
	3 dia.	E32-D221B 2M	450	210	130	40
	M4	E32-D21B 2M				
	M6	E32-D11 2M	1,260	520	360	100
	Square	E32-D25XB 2M	360	150	90	30

Heat-resistant Models

Sensing method	Size	Model	Sensing distance (mm)				
			Giga mode	Standard mode	High-speed mode	Super-high-speed mode	
Through-beam	100°C	E32-T51R 2M	2,400	1,200	840	225	
	150°C	E32-T51 2M	4,000*1	2,250	1,500	400	
	200°C	E32-T81R-S 2M	1,500	820	540	140	
	350°C	E32-T61-S 2M	2,520	1,350	900	240	
Reflective	100°C	E32-D51R 2M	1,000	420	280	80	
	150°C	E32-D51 2M	1,680	670	480	144	
	200°C	E32-D81R-S 2M	630	270	180	54	
	300°C	E32-A08H2 2M	10 to 20				---
		E32-A09H2 2M	20 to 30 (center 25)				---
	350°C	E32-D611-S 2M	630	270	180	54	
		E32-D61-S 2M					
	400°C	E32-D73-S 2M	420	180	120	36	

*1. The fiber length is 2 m on each side, so the sensing distance is given as 4,000 mm.

Area Detection Models

Sensing method	Type	Sensing width	Model	Sensing distance (mm)			
				Giga mode	Standard mode	High-speed mode	Super-high-speed mode
Through-beam	Area	11 mm	E32-T16PR 2M	4,000*1	2,550	1,680	440
			E32-T16JR 2M	4,000*1	2,250	1,440	380
		30 mm	E32-T16WR 2M	4,000*1	3,900	2,550	680
Reflective	Array	11 mm	E32-D36P1 2M	1,050	450	300	90

*1. The fiber length is 2 m on each side, so the sensing distance is given as 4,000 mm.

Liquid-level Detection Models

Sensing method	Tube diameter	Feature	Model	Sensing distance (mm)			
				Giga mode	Standard mode	High-speed mode	Super-high-speed mode
Tube-mounting	3.2, 6.4, or 9.5 dia	Stable residual quantity detection	E32-A01 5M	Applicable tube: Transparent tube with a diameter of 3.2, 6.4, or 9.5 mm, Recommended wall thickness: 1 mm			
	8 to 10 dia	Mounting at multiple levels	E32-L25T 2M	Applicable tube: Transparent tube with a diameter of 8 to 10 mm, Recommended wall thickness: 1 mm			
	No restrictions	Large tubes	E32-D36T 5M	Applicable tube: Transparent tube (no restrictions on diameter)			
Liquid contact (heat-resistant up to 200°C)	---	---	E32-D82F1 4M	Liquid-contact type			

Vacuum-resistant Models

Sensing method	Heat-resistant temperature	Model	Sensing distance (mm)			
			Giga mode	Standard mode	High-speed mode	Super-high-speed mode
Through-beam	120°C	E32-T51V 1M	1,080	600	390	100
		E32-T51V 1M + E39-F1V	2,000*1	2,000*1	2,000*1	520
	200°C	E32-T84SV 1M	2,000*1	1,420	960	260

*1. The fiber length is 1 m on each side, so the sensing distance is given as 2,000 mm.

Models for FPD, Semiconductors, and Solar Cells

Sensing method	Application	Operating temperature	Model	Sensing distance (mm)			
				Giga mode	Standard mode	High-speed mode	Super-high-speed mode
Limited-reflective	Glass presence detection	70°C	E32-L16-N 2M	0 to 15			0 to 12
			E32-A08 2M	10 to 20			---
	Glass substrate alignment	300°C	E32-A08H2 3M	12 to 30			---
			E32-A12 2M	15 to 38			---
	Glass substrate mapping	70°C	E32-A09 2M	20 to 30 (center 25)			---
			E32-A09H2 2M				---
Wet processes: Cleaning, Resist developing and etching	60°C	E32-L11FP 5M	8 to 20 mm from tip of lens (Recommended sensing distance: 11 mm), 19 to 31 mm from center of mounting hole A (Recommended sensing distance: 22 mm)				
		E32-L11FS 5M	8 to 20 mm from tip of lens (Recommended sensing distance: 11 mm), 32 to 44 mm from center of mounting hole A (Recommended sensing distance: 35 mm)				
Through-beam	Wafer mapping	70°C	E32-A03 2M	4,000*1	2,670	1,800	500
			E32-A03-1 2M				
			E32-A04 2M	1,920	1,020	670	200
			E32-T24SR 2M	4,000*1	3,300	2,190	580
			E32-T24S 2M	4,000*1	3,900	2,610	700

*1. The fiber length is 2 m on each side, so the sensing distance is given as 4,000 mm.

I/O Circuit Diagrams

NPN Output

Model	Operation mode	Timing chart	L/D indicator	Output circuit
E3NX-FA11 E3NX-FA6	Light-ON		L lit.	
	Dark-ON		D lit.	
E3NX-FA21	Light-ON		L lit.	
	Dark-ON		D lit.	
E3NX-FA7	Light-ON		L lit.	
	Dark-ON		D lit.	
E3NX-FA7TW	Light-ON		L lit.	
	Dark-ON		D lit.	

PNP Output

Model	Operation mode	Timing chart	L/D indicator	Output circuit
E3NX-FA41 E3NX-FA8	Light-ON	<p>Incident light </p> <p>No incident light </p> <p>OUT indicator Lit (orange) </p> <p>Not lit </p> <p>Output ON </p> <p>transistor OFF </p> <p>Load Operate (e.g., relay) </p> <p>Reset </p> <p>(Between blue and black leads)</p>		
	Dark-ON	<p>Incident light </p> <p>No incident light </p> <p>OUT indicator Lit (orange) </p> <p>Not lit </p> <p>Output ON </p> <p>transistor OFF </p> <p>Load Operate (e.g., relay) </p> <p>Reset </p> <p>(Between blue and black leads)</p>		
E3NX-FA51	Light-ON	<p>ch1/ Incident light </p> <p>ch2 No incident light </p> <p>OUT indicator Lit (orange) </p> <p>Not lit </p> <p>Output ON </p> <p>transistor OFF </p> <p>Load Operate (e.g., relay) </p> <p>Reset </p> <p>(Between blue and black (orange) leads)</p>		
	Dark-ON	<p>ch1/ Incident light </p> <p>ch2 No incident light </p> <p>OUT indicator Lit (orange) </p> <p>Not lit </p> <p>Outputs ON </p> <p>transistor OFF </p> <p>Load Operate (e.g., relay) </p> <p>Reset </p> <p>(Between blue and black (orange) leads)</p>		
E3NX-FA9	Light-ON	<p>Incident light </p> <p>No incident light </p> <p>OUT indicator Lit (orange) </p> <p>Not lit </p> <p>Output ON </p> <p>transistor OFF </p> <p>Load Operate (e.g., relay) </p> <p>Reset </p> <p>(Between blue and black leads)</p>		
	Dark-ON	<p>Incident light </p> <p>No incident light </p> <p>OUT indicator Lit (orange) </p> <p>Not lit </p> <p>Output ON </p> <p>transistor OFF </p> <p>Load Operate (e.g., relay) </p> <p>Reset </p> <p>(Between blue and black leads)</p>		
E3NX-FA9TW	Light-ON	<p>ch1/ Incident light </p> <p>ch2 No incident light </p> <p>OUT indicator Lit (orange) </p> <p>Not lit </p> <p>Output ON </p> <p>transistor OFF </p> <p>Load Operate (e.g., relay) </p> <p>Reset </p> <p>(Between blue and black (orange) leads)</p>		
	Dark-ON	<p>ch1/ Incident light </p> <p>ch2 No incident light </p> <p>OUT indicator Lit (orange) </p> <p>Not lit </p> <p>Outputs ON </p> <p>transistor OFF </p> <p>Load Operate (e.g., relay) </p> <p>Reset </p> <p>(Between blue and black (orange) leads)</p>		

Nomenclature

E3NX-FA11/FA41/FA6/FA8/FA7/FA9

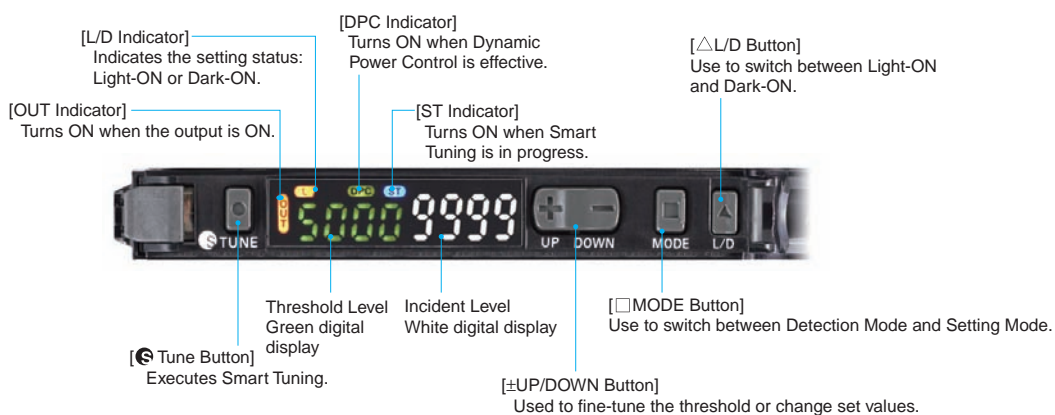

E3NX-FA21/FA51/FA7TW/FA9TW/FA0

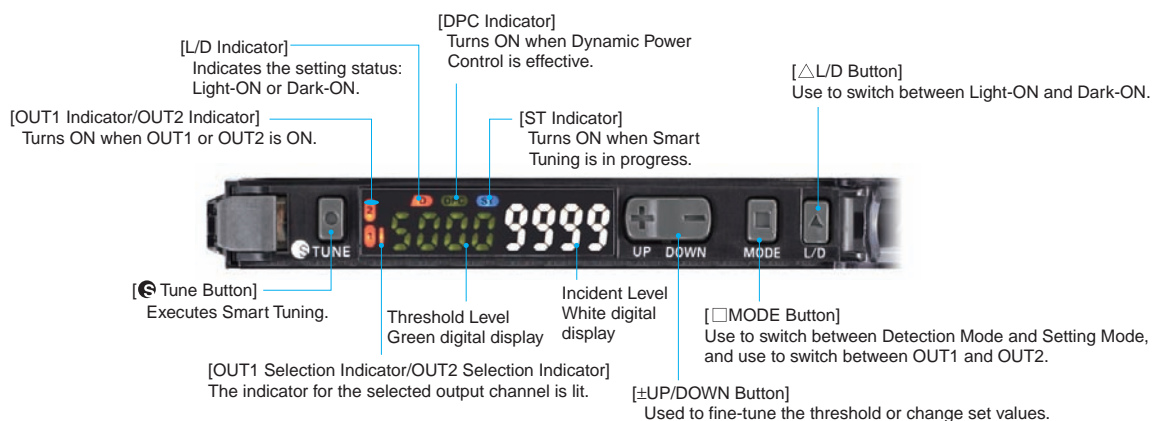

Safety Precautions

To ensure safe operation, be sure to read and follow the Instruction Manual provided with the Sensor.

WARNING

This product is not designed or rated for ensuring safety of persons either directly or indirectly. Do not use it for such purposes.



CAUTION

Do not use the product with voltage in excess of the rated voltage. Excess voltage may result in malfunction or fire.



Never use the product with an AC power supply. Otherwise, explosion may result.



Precautions for Safe Use

The following precautions must be observed to ensure safe operation of the Sensor.

1. Do not use the Sensor in environments subject to flammable or explosive gases.
2. Do not use the Sensor in environments subject to exposure to water, oil, chemicals, etc.
3. Do not install the Sensor in environments subject to intense electric fields or ferromagnetic fields.
4. Do not attempt to disassemble, repair, or modify the Sensor in any way.
5. Do not apply voltages or currents that exceed the rated ranges.
6. Do not use the Sensor in any atmosphere or environment that exceeds the ratings.
7. Wire the power supply correctly, including the polarity.
8. Connect the load correctly.
9. Do not short both ends of the load.
10. Do not use the Sensor if the case is damaged.
11. When disposing of the Sensor, treat it as industrial waste.
12. High-voltage lines and power lines must be wired separately from this Sensor. Wiring them together or placing them in the same duct may cause induction, resulting in malfunction or damage.
13. Burn injury may occur. The Sensor surface temperature rises depending on application conditions, such as the ambient temperature and the power supply voltage. Use caution when operating or cleaning the Sensor.
14. Before setting the Sensor, take appropriate safety measures, such as stopping the equipment.

Precautions for Correct Use

1. Do not install the Sensor in the following locations.
 - Locations subject to direct sunlight
 - Locations subject to condensation due to high humidity
 - Locations subject to corrosive gas
 - Locations subject to vibration or mechanical shocks exceeding the rated values
2. Use an extension cable with a minimum thickness of 0.3 mm² and less than 100 m long.
3. Do not subject the cable to more than the following forces. Pull: 40 N; torque: 0.1 N·m; pressure: 20 N; bending: 3 kg
4. The Sensor is ready to operate 200 ms after the power supply is turned ON. If the Sensor and load are connected to power supplies separately, turn ON the power supply to the Sensor first.
5. The Sensor may require some time after it is turned ON to ensure a stable light reception intensity, depending on the operational environment.
6. When using Amplifier Units with Wire-saving Connectors, attach the protective stickers (provided with E3X-CN-series Connectors) on the unused power pins to prevent electrical shock and short circuiting. When using Amplifier Units with Connectors for Communications Units, attach the protective caps.

Amplifier Unit with Wire-saving Connector

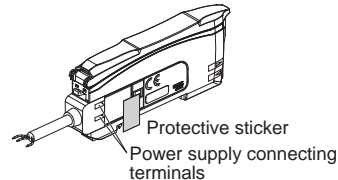

Amplifier Unit with Connector for Communications Unit

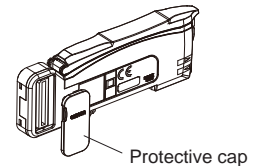

7. Output pulses may occur when the power supply is turned OFF. Turn OFF the power supply to the load or load line first.
8. Make sure that the power supply is turned OFF before connecting, separating, or adding Amplifier Units.
9. Do not pull on or apply excessive pressure or force (exceeding 9.8 N) to the Fiber Unit when it is attached to the Amplifier Unit.
10. The E3X-MC11, E3X-MC11-SV2, and E3X-MC11-S Mobile Consoles cannot be used.
11. Mutual interference prevention does not work with the E3X-HD, E3X-DA-S, E3X-DA-N, E3X-SD, or E3X-NA.
12. The E3NW-ECT Sensor Communications Unit can be used with the E3NX-FA0, but the E3X-DRT21-S, E3X-CRT, and E3X-ECT Communications Units cannot be used.
13. Always keep the protective cover in place when using the Amplifier Unit. Not doing so may cause malfunction.
14. Do not use thinner, benzene, acetone, or kerosene for cleaning.

Dimensions

Tolerance class IT16 applies to dimensions in this data sheet unless otherwise specified.

Fiber Amplifier Units

Pre-wired Amplifier Units

- E3NX-FA11
- E3NX-FA21
- E3NX-FA41
- E3NX-FA51

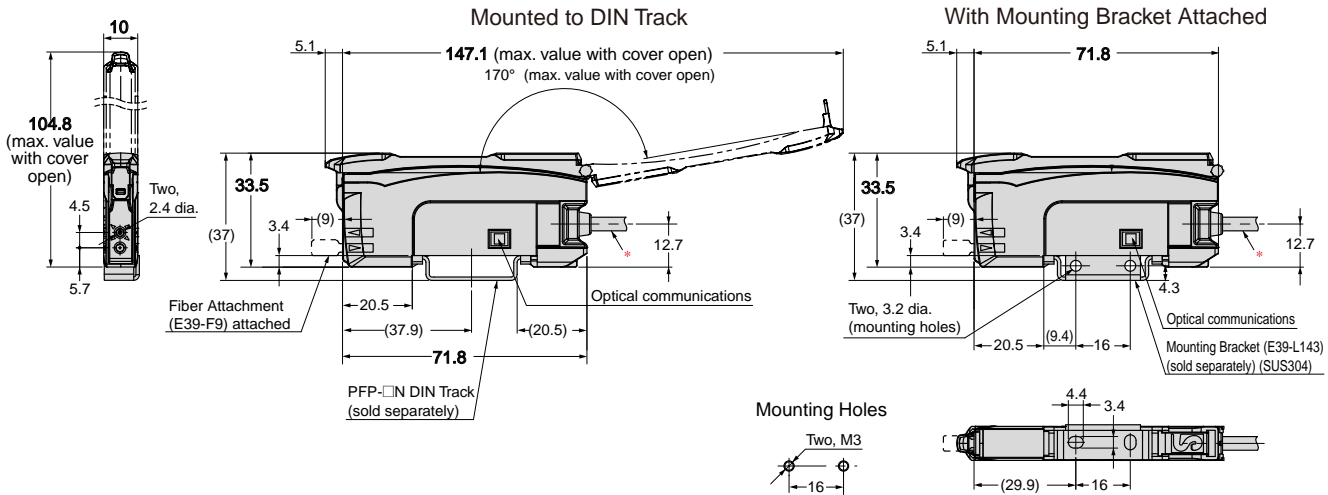
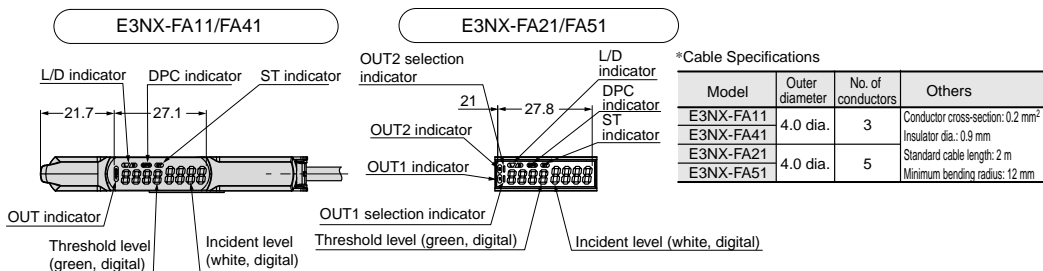

Amplifier Units with Wire-saving Connectors

- E3NX-FA6
- E3NX-FA7
- E3NX-FA7TW
- E3NX-FA8
- E3NX-FA9
- E3NX-FA9TW

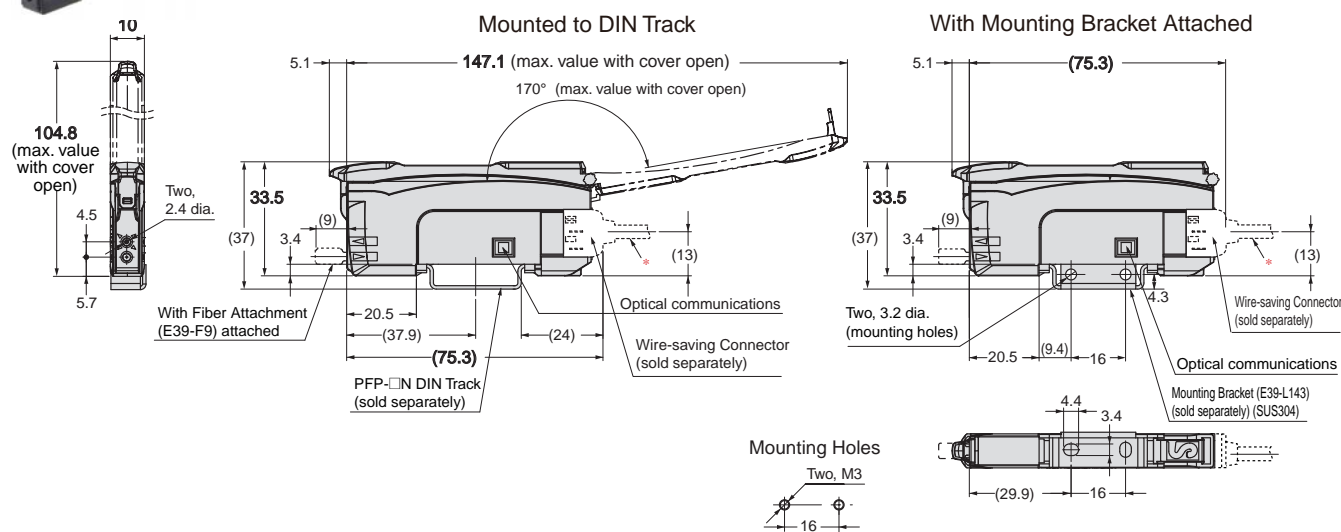
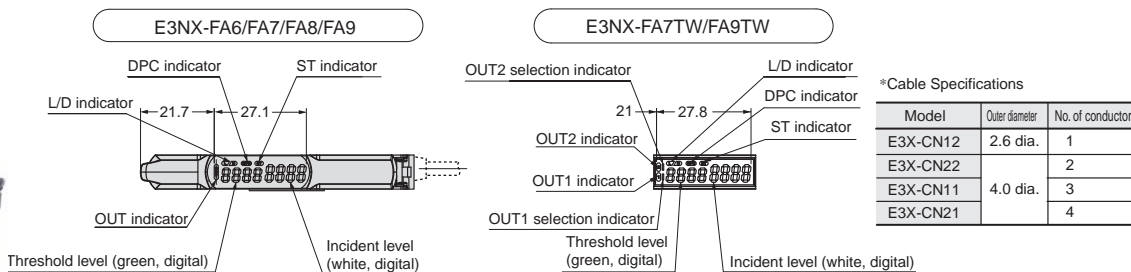

Amplifier Unit with Connector for Sensor Communications Unit

E3NX-FA0 Available soon.

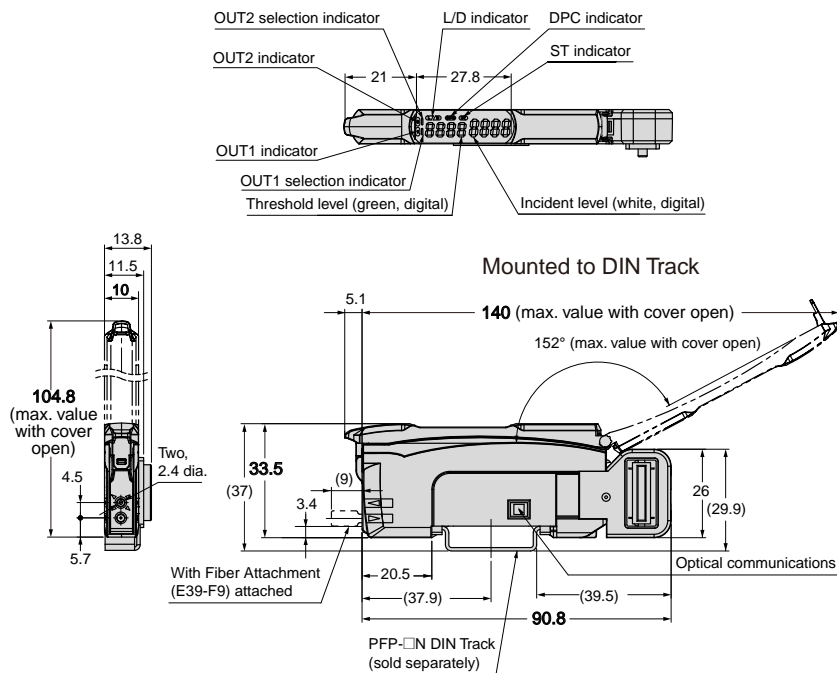

Accessories (Sold Separately)

Wire-saving Connectors

Master Connector

E3X-CN11
 E3X-CN21

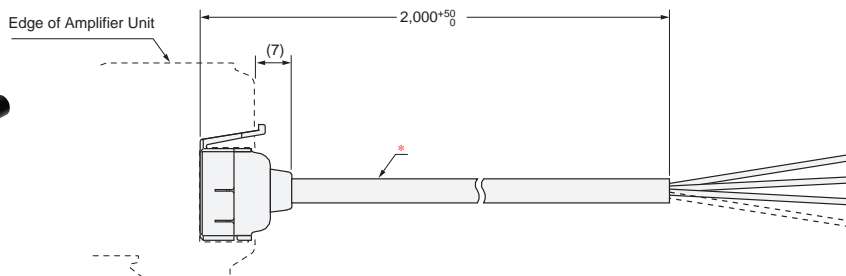

* E3X-CN11: 4-dia. cable with 3 conductors, Standard cable length: 2 m (Conductor cross-section: 0.2 mm² (AWG24), Insulator diameter: 1.1 mm)
 E3X-CN21: 4-dia. cable with 4 conductors, Standard cable length: 2 m (Conductor cross-section: 0.2 mm² (AWG24), Insulator diameter: 1.1 mm)

Slave Connector

E3X-CN12
 E3X-CN22

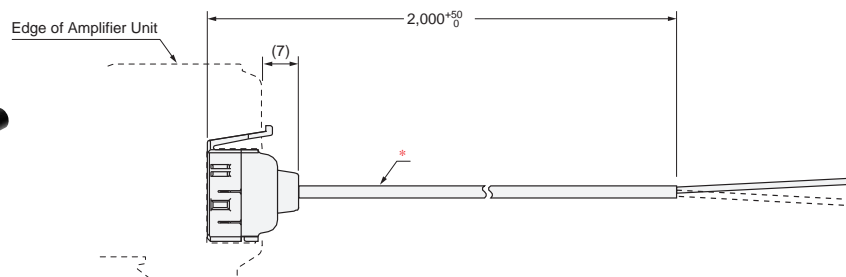

* E3X-CN12: 2.6-dia. cable with 1 conductor, Standard cable length: 2 m (Conductor cross-section: 0.2 mm² (AWG24), Insulator diameter: 1.1 mm)
 E3X-CN22: 4-dia. cable with 2 conductors, Standard cable length: 2 m (Conductor cross-section: 0.2 mm² (AWG24), Insulator diameter: 1.1 mm)

Mounting Bracket
E39-L143

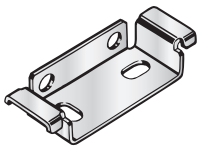

Material: Stainless steel (SUS304)

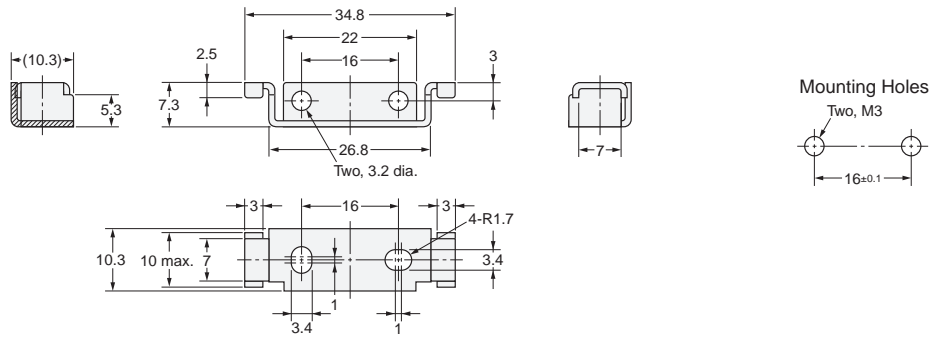

DIN Track
PFP-100N
PFP-50N



Material: Aluminum

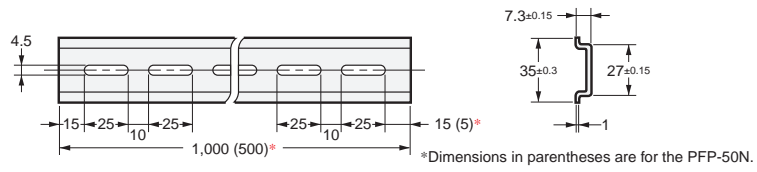

PFP-100N2



Material: Aluminum

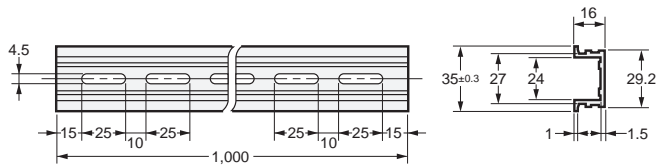

End Plate
PFP-M



Materials: Iron, zinc plating

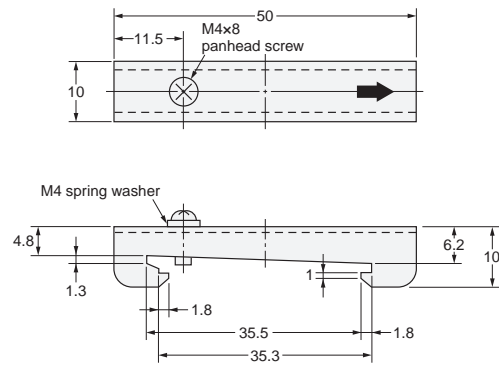

Related Products

Sensor Communications Unit

E3NW-ECT Available soon.

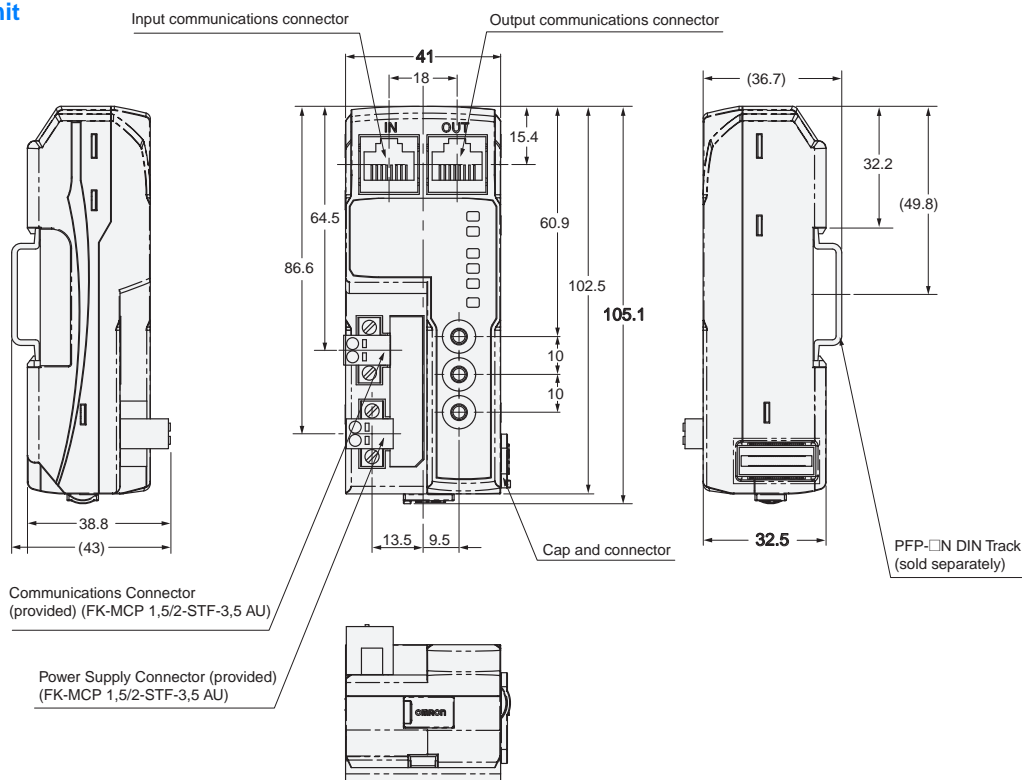

Sensor Dispersion Unit

E3NW-DS Available soon.

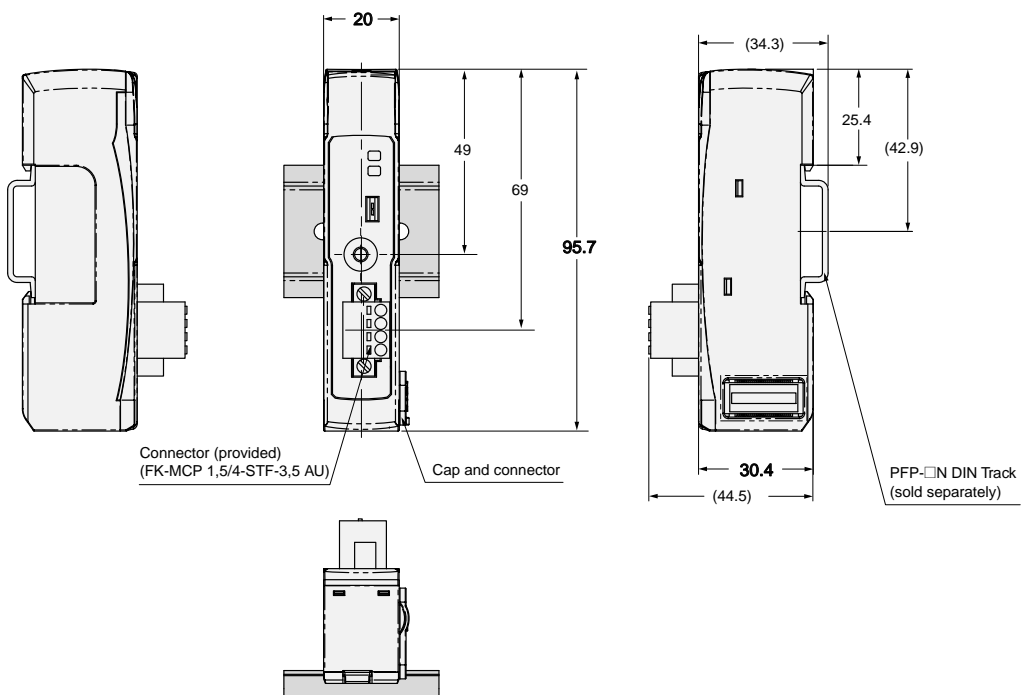

Read and Understand This Catalog

Please read and understand this catalog before purchasing the products. Please consult your OMRON representative if you have any questions or comments.

Warranty and Limitations of Liability

WARRANTY

OMRON's exclusive warranty is that the products are free from defects in materials and workmanship for a period of one year (or other period if specified) from date of sale by OMRON.

OMRON MAKES NO WARRANTY OR REPRESENTATION, EXPRESS OR IMPLIED, REGARDING NON-INFRINGEMENT, MERCHANTABILITY, OR FITNESS FOR PARTICULAR PURPOSE OF THE PRODUCTS. ANY BUYER OR USER ACKNOWLEDGES THAT THE BUYER OR USER ALONE HAS DETERMINED THAT THE PRODUCTS WILL SUITABLY MEET THE REQUIREMENTS OF THEIR INTENDED USE. OMRON DISCLAIMS ALL OTHER WARRANTIES, EXPRESS OR IMPLIED.

LIMITATIONS OF LIABILITY

OMRON SHALL NOT BE RESPONSIBLE FOR SPECIAL, INDIRECT, OR CONSEQUENTIAL DAMAGES, LOSS OF PROFITS OR COMMERCIAL LOSS IN ANY WAY CONNECTED WITH THE PRODUCTS, WHETHER SUCH CLAIM IS BASED ON CONTRACT, WARRANTY, NEGLIGENCE, OR STRICT LIABILITY.

In no event shall the responsibility of OMRON for any act exceed the individual price of the product on which liability is asserted.

IN NO EVENT SHALL OMRON BE RESPONSIBLE FOR WARRANTY, REPAIR, OR OTHER CLAIMS REGARDING THE PRODUCTS UNLESS OMRON'S ANALYSIS CONFIRMS THAT THE PRODUCTS WERE PROPERLY HANDLED, STORED, INSTALLED, AND MAINTAINED AND NOT SUBJECT TO CONTAMINATION, ABUSE, MISUSE, OR INAPPROPRIATE MODIFICATION OR REPAIR.

Application Considerations

SUITABILITY FOR USE

OMRON shall not be responsible for conformity with any standards, codes, or regulations that apply to the combination of products in the customer's application or use of the products.

At the customer's request, OMRON will provide applicable third party certification documents identifying ratings and limitations of use that apply to the products. This information by itself is not sufficient for a complete determination of the suitability of the products in combination with the end product, machine, system, or other application or use.

The following are some examples of applications for which particular attention must be given. This is not intended to be an exhaustive list of all possible uses of the products, nor is it intended to imply that the uses listed may be suitable for the products:

- Outdoor use, uses involving potential chemical contamination or electrical interference, or conditions or uses not described in this catalog.
- Nuclear energy control systems, combustion systems, railroad systems, aviation systems, medical equipment, amusement machines, vehicles, safety equipment, and installations subject to separate industry or government regulations.
- Systems, machines, and equipment that could present a risk to life or property.

Please know and observe all prohibitions of use applicable to the products.

NEVER USE THE PRODUCTS FOR AN APPLICATION INVOLVING SERIOUS RISK TO LIFE OR PROPERTY WITHOUT ENSURING THAT THE SYSTEM AS A WHOLE HAS BEEN DESIGNED TO ADDRESS THE RISKS, AND THAT THE OMRON PRODUCTS ARE PROPERLY RATED AND INSTALLED FOR THE INTENDED USE WITHIN THE OVERALL EQUIPMENT OR SYSTEM.

PROGRAMMABLE PRODUCTS

OMRON shall not be responsible for the user's programming of a programmable product, or any consequence thereof.

Disclaimers

CHANGE IN SPECIFICATIONS

Product specifications and accessories may be changed at any time based on improvements and other reasons.

It is our practice to change model numbers when published ratings or features are changed, or when significant construction changes are made. However, some specifications of the products may be changed without any notice. When in doubt, special model numbers may be assigned to fix or establish key specifications for your application on your request. Please consult with your OMRON representative at any time to confirm actual specifications of purchased products.

DIMENSIONS AND WEIGHTS

Dimensions and weights are nominal and are not to be used for manufacturing purposes, even when tolerances are shown.

PERFORMANCE DATA

Performance data given in this catalog is provided as a guide for the user in determining suitability and does not constitute a warranty. It may represent the result of OMRON's test conditions, and the users must correlate it to actual application requirements. Actual performance is subject to the OMRON Warranty and Limitations of Liability.

ERRORS AND OMISSIONS

The information in this document has been carefully checked and is believed to be accurate; however, no responsibility is assumed for clerical, typographical, or proofreading errors, or omissions.

2013.1

In the interest of product improvement, specifications are subject to change without notice.

OMRON Corporation
Industrial Automation Company

<http://www.ia.omron.com/>

(c)Copyright OMRON Corporation 2013 All Right Reserved.